

Motion Accessories

VEX Pneumatics Kit

Pneumatic cylinders deliver fast and powerful linear motion that is useful in a variety of applications. Use pneumatics to power your robot's claw, kicker device or any mechanism that requires fast deployment as well as considerable force if necessary. In particular, pneumatics are useful in applications requiring only two positions (open/closed).

YOU MUST HAVE A PROGRAMMING KIT TO USE PNEUMATICS!

Unlike a motor, pneumatic cylinders get their energy from the compressed air stored in the pneumatic reservoir. When the compressed air is directed into the front of the cylinder, it applies pressure to the piston causing it to retract. Similarly, when the compressed air is directed into the back of the cylinder, it pushes against the piston causing it to extend.

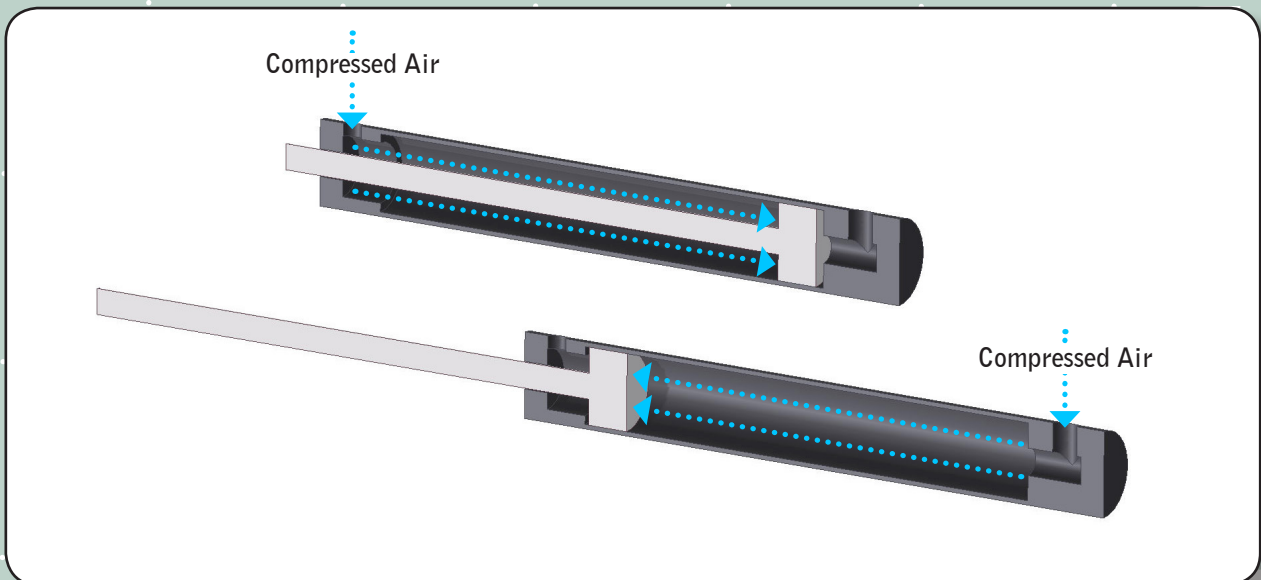

the airflow between the reservoir and the pneumatic cylinders is controlled by an electric valve called a solenoid. The pneumatic solenoids included in this kit have only two states, forward or reverse. Subsequently the VEX pneumatic cylinders have only two controllable positions, completely retracted or completely extended.

Pneumatic solenoids are controlled by the microcontroller through the use of digital outputs. Once the system is correctly assembled, a program can be written to control the digital outputs that the solenoids are plugged into. For further help with programming pneumatics, see the sample programs included with your programming software.

Limited 90-day Warranty

This product is warranted by VEX Robotics against manufacturing defects in material and workmanship under normal use for ninety (90) days from the date of purchase from authorized Innovation First dealers. For complete warranty details and exclusions, check with your dealer.

VEX Robotics, Inc.
1519 IH 30 W
Greenville, TX 75402

07/12

For More Information, and additional Parts & Pieces refer to:

www.VEXRobotics.com

Motion Accessories

VEX Pneumatics Kit (continued)

Section 1: Component Assembly Instructions

1. Remove the protective seals from the reservoir openings and install the reservoir fitting and reservoir tire pump fitting as shown using a standard 7/16-inch wrench. To ensure a proper seal, tighten the fitting until all of the thread tape is hidden from view.

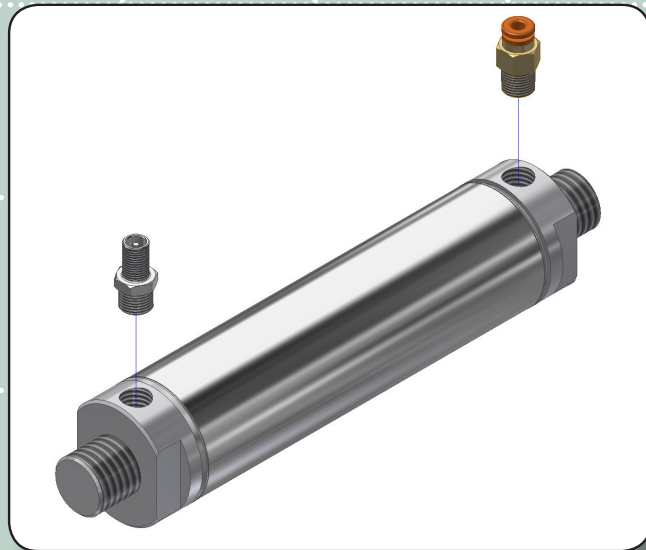

2. Install the flow control fitting and brass cylinder fitting in each cylinder as shown. Using a small pair of pliers, carefully tighten the fitting to approximately $\frac{1}{4}$ turn past finger-tight.

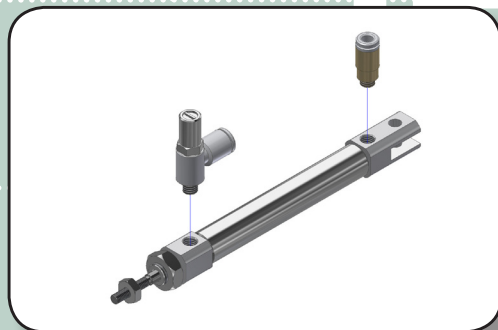

3. Install the rod pivot on the cylinder rod as shown using (2) 6-40 nuts. To secure the cylinder rod pivot, tighten the mounting nuts using a 5/16-inch wrench.

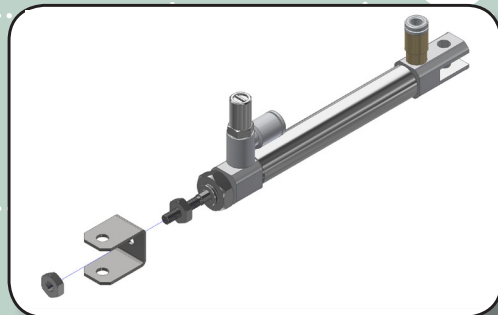

4. Install the cylinder mount on the back of the cylinder as shown using a VEX standard 1-inch long 8-32 screw and 8-32 nylock nut.

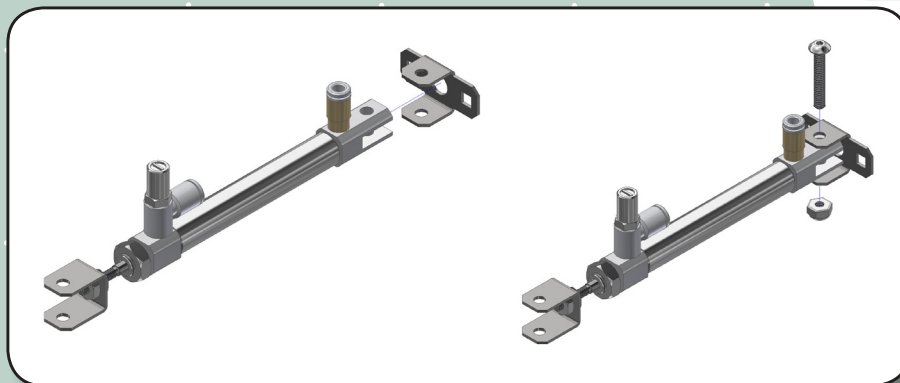

Motion Accessories

VEX Pneumatics Kit (continued)

5. Install a solenoid fitting into the center hole on the bottom of the solenoid. Tighten the fitting to approximately $\frac{1}{4}$ turn past finger-tight.

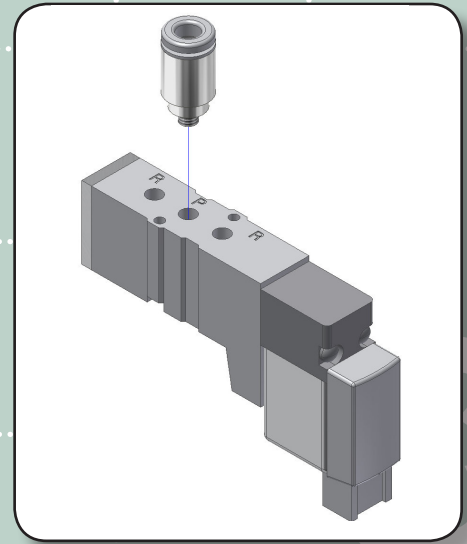

6. Install two more solenoid fittings into the holes marked A and B on the top of the solenoid. Tighten the fittings to approximately $\frac{1}{4}$ turn past finger-tight.

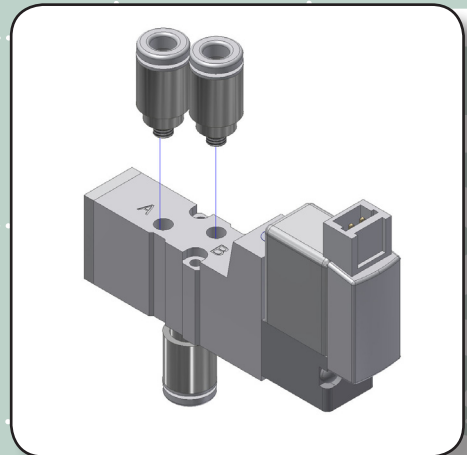

7. Plug the solenoid drive cable into the solenoid as shown. Note that the connector is keyed to prevent it from being plugged in the wrong way.

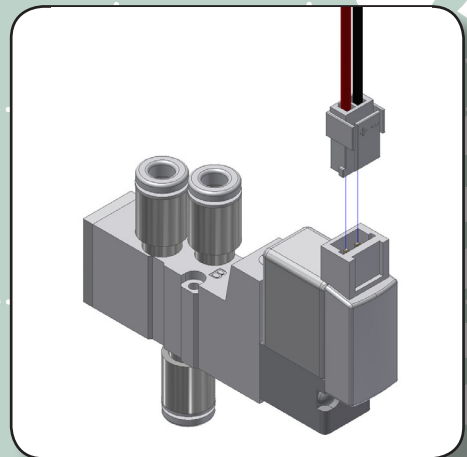

VEX Pneumatics Kit (continued)

Section 2: Assembling the System

Pneumatic Tubing

Included in this kit is 5 feet of 4mm OD pneumatic tubing. This tubing serves as the piping which carries air throughout the system. In order to assemble a complete system, the tubing will need to be cut to the specific lengths that you need. A pair of scissors or a small pair of wire cutters works well for this.

When cutting a length of tubing, it is always a good idea to cut each section slightly longer than necessary. A tube that is overly tight or kinked could cause the system to leak.

Please note: It is very important to cut the tubing cleanly and perpendicular to its length. A crooked or jagged cut will lead to air leaks in the system. To connect the individual components in the system, simply insert the tubing into the one-touch valves. To remove a tube from the onetouch valve, hold down the plastic button that surrounds the valve entrance as you pull the tube out.

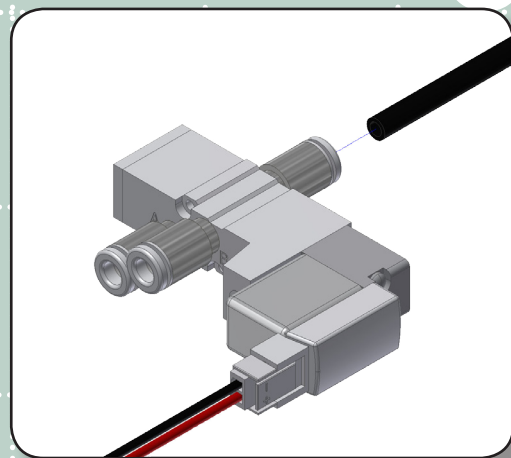

Solenoid Valve

After mounting one-touch fittings into the ports labeled P, A and B on the solenoid (see Section I for instructions), it can be installed into the pneumatic system. The hose connected to port P on the bottom of the solenoid should lead back to the pneumatic reservoir. Ports A and B on the solenoid should be connected to the two fitting on the pneumatic cylinder. While it is not necessary to connect port A or B to a specific fitting on the cylinder, reversing these connections is a good way to invert the default state of the cylinder. The solenoid will open port B by default, meaning that the cylinder fitting connected to this port will receive pressure when the digital output is set to low or the robot is turned off.

Note: A way to conserve pressure in your pneumatic system is to mount the solenoid as close as possible to the cylinder. Excess tubing between the solenoid and the cylinder will cause your system to lose more pressure with each stroke.

Motion Accessories

VEX Pneumatics Kit (continued)

Tire Pump Fitting

One of the reservoir fittings is equipped with a schrader valve that will be used to charge the pneumatic system. This fitting can be used with any standard bike pump or air compressor.

Note: The maximum recommended input pressure for the VEX Pneumatic System is 100 psi (0.7 MPa). Charging your system to a greater pressure is considered unsafe and is not legal for VEX Robotics Competition use. To prevent overcharging, we recommend using a quality bike pump that is equipped with a pressure gauge.



Pressure Regulator

The pressure regulator allows you to adjust the maximum amount of pressure that will reach the cylinders. While the pressure regulator is not a necessary component in every pneumatic system, it is useful in applications that do not require the cylinder's full force. Also, by reducing the applied pressure to the cylinders, you can conserve pressure and equalize performance in the pneumatic system.

The pressure regulator must be installed so that the hose connected to the blue one-touch fitting leads to the cylinders and the hose connected to the brass connector leads to the reservoir.

When correctly installed, turning the adjustment screw on the pressure regulator to the left (unscrewing) will decrease the maximum amount of pressure that reaches the cylinders. Turning the adjustment screw to the right (screwing in) will increase the maximum amount of pressure that reaches the cylinders thus increasing their initial performance but using more pressure for each stroke. Turning the adjustment screw all the way to the right (all the way in) will completely open the valve and allow the full system pressure to reach the cylinders.

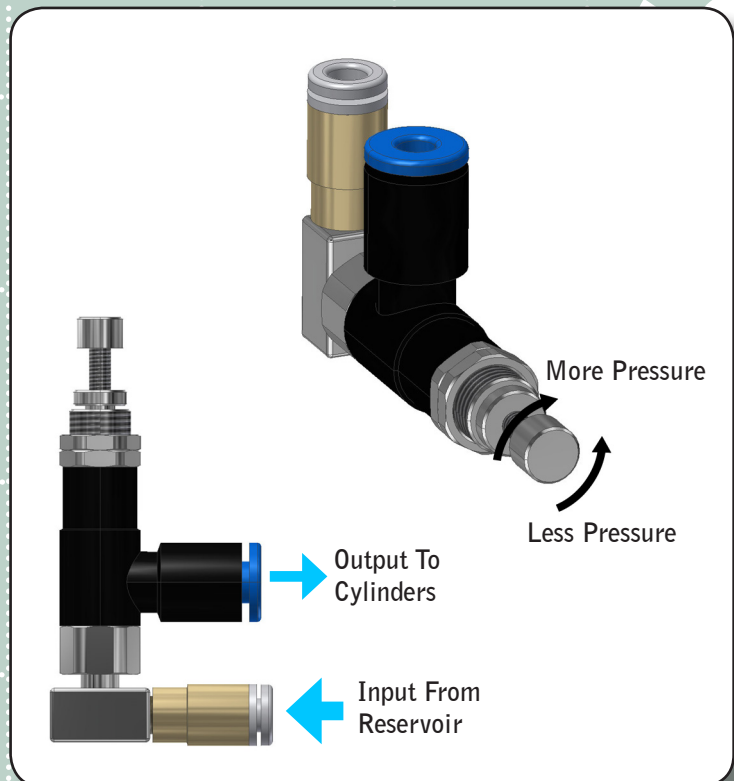

Motion Accessories

VEX Pneumatics Kit (continued)

Manual On/Off Switch

The manual On/Off switch is a simple valve that allows you to close off pressure to the cylinders without emptying the entire system of air pressure. This is useful if you need the cylinders to temporarily move freely in order to remove a game object or fix a mechanism.

Please note the switch must be installed in a specific orientation. The pneumatic hose coming from the reservoir should be connected to the fitting with the arrow on it (the arrow should face away from the reservoir).

Note: When the switch is closed pressure is released from the Output Side.

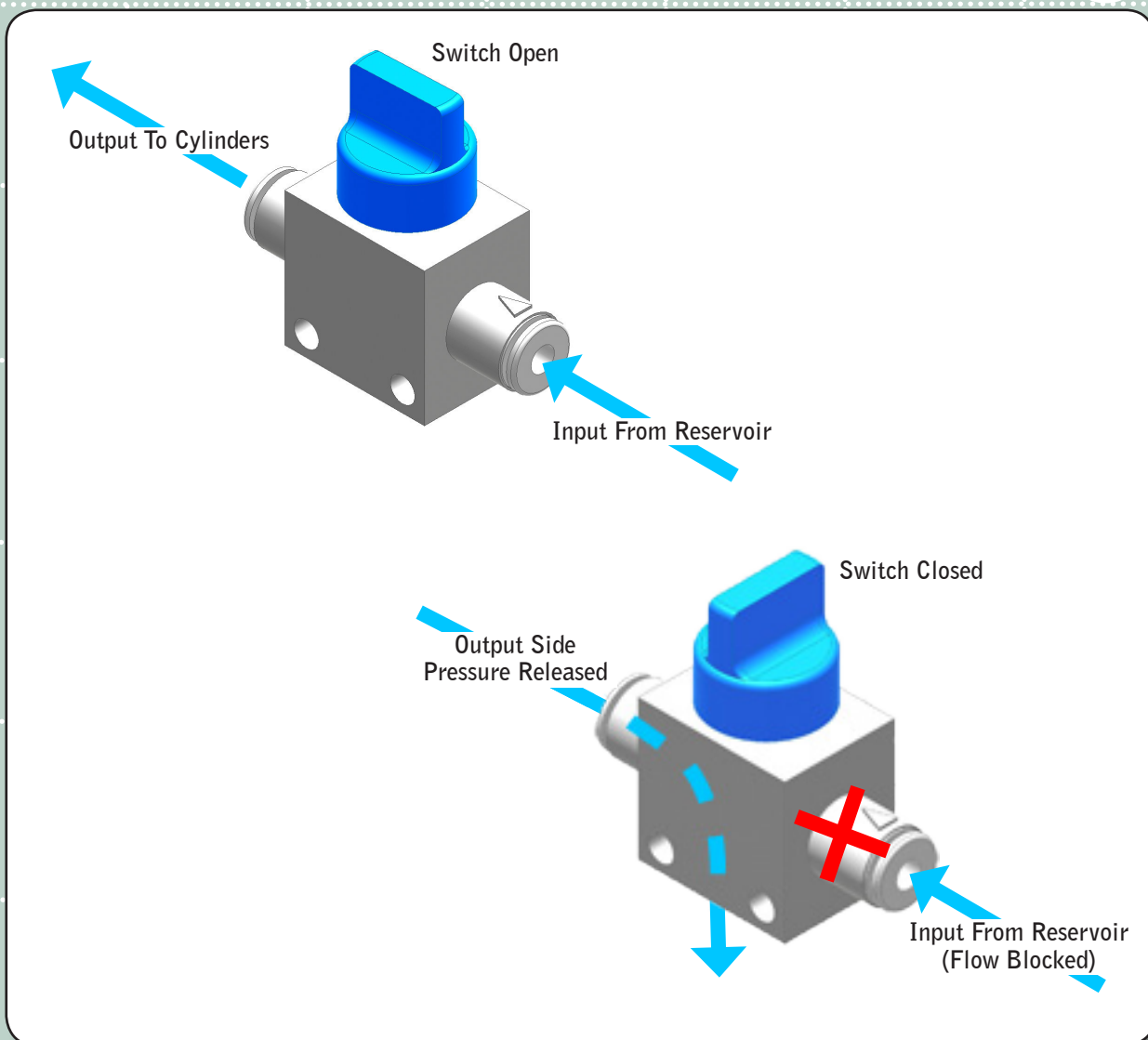

VEX Pneumatics Kit (continued)

Complete System

A complete pneumatic system using two cylinders is shown below. A single pneumatic system can supply air to any number of cylinders. However, using additional cylinders will cause your system to lose pressure more quickly. In general we do not recommend using more than two cylinders for each reservoir in your system. If you have an application that requires more than two cylinders, it may be necessary install an additional reservoir. The T-fitting which is included in this kit can be used to supply pressure to additional components in your system.

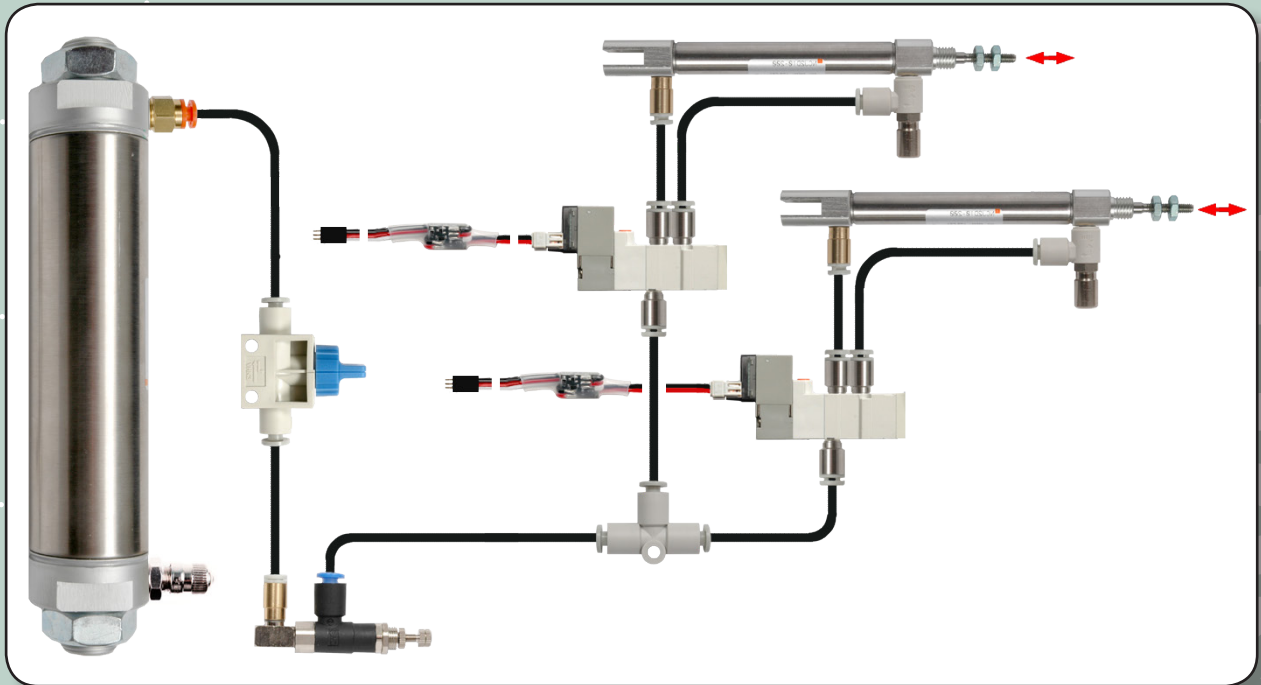

VEX Pneumatics Kit (continued)

Section 3: System Details

Reservoir Specifications:

Length	7.87 in (20 cm)
Diameter	1.57 in (4 cm)
Cylinder	Wall 0.125 in (3.2 mm)
Weight	0.68 lbs (308 g)
Volume	5.07 fl oz (150 ml)
Cylinder Strokes	45 Strokes from 100 psi to 25 psi

Cylinder Specifications:

Compressed Length	5.5 in (13.97 cm)
Stroke	2 in (5.08 cm)
Cylinder Bore	0.39 in (10 mm)
Weight	0.09 lbs (20 g)
Maximum Pressure	100 psi (0.7 MPa)
Maximum Output Force	12 lbs (54 N)

The equation for calculating the Output Force for a specific pressure is given as:

$$\text{(Cross Sectional Area of Cylinder) x (Internal Air Pressure) = Force}$$

The cylinders bore of the VEX Pneumatic Cylinders is .39 in (10 mm). From this we can calculate the cross sectional area of the cylinder by using the equation for the area of a circle:

$$\text{(Diameter / 2)}^2 \times \text{Pi} = \text{Area}$$

As we are given the cylinder bore (inside diameter) and we know that $\text{Pi} \approx 3.14$, we can calculate the area to be:

$$(.39 \text{ in} / 2)^2 \times 3.14 = .12 \text{ in}^2$$

We can now plug this number into our original equation and calculate the cylinder output force:

$$.12 \text{ in}^2 \times 100 \text{ psi} = \underline{12 \text{ Pounds of Force (at 100 psi)}}$$

accessories